

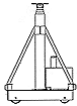

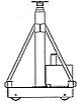

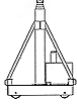

Product Literature

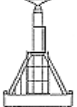

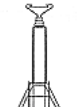
The Gantry Line

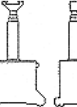
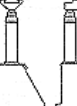
	MODEL	CAPACITY	NO. OF BASES	POWER UNITS	HEIGHTS	
					RETRACTED	EXTENDED
	2020SC 10 Ton cylinder	20 ton	2 station	Self-contained in bases	6'0"	16'0"
	2033SC 16.5 ton cylinder	33 ton	2 station	Self-contained in bases	6'0"	16'0"
	2033SCT 16.5 ton cylinder	33 ton	2 station	Self-contained in bases	7'6"	20'6"
	2080 4160 40 ton cylinder	80 ton 160 ton	2 station 4 station	one 50 gallon one 100 gallon	8'0"	19'0"
	21A 42A 50 ton cylinder	100 ton 200 ton	2 station 4 station	one 100 gallon one 200 gallon	10'0"	21'8"
	21.5A (4 stage) 43A (4 stage) 75 ton cylinder	150 ton 300 ton	2 station 4 station	one 130 gallon one 300 gallon	8'0"	21'8"
	22A 44A 100 ton cylinder	200 ton 400 ton	2 station 4 station	one 200 gallon one 400 gallon	10'0"	27'6"
	2200 4400 125 ton cylinder	250 ton 500 ton	2 station 4 station	one 200 gallon one 400 gallon	10'0"	27'6"
	24A 48A 100 ton cylinder	400 ton 800 ton	2 station 4 station	one 400 gallon two 400 gallon	10'0"	27'6"
	2400 4800 125 ton cylinder	500 ton 1000 ton	2 station 4 station	one 400 gallon two 400 gallon	10'0"	27'6"

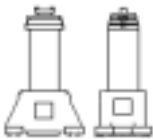
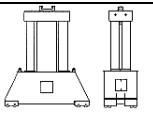
The Power Tower Line

MODEL	CAPACITY	NO. OF BASES	POWER UNITS	HEIGHTS	
				RETRACTED	EXTENDED
22PT150 24PT300 L/LS/WS	150 ton 300 ton	2 station 4 station	one 130 gallon two 130 gallon	10'0"	23'0"
22PT250 24PT500 S/LS/WS	250 ton 500 ton	2 station 4 station	one 130 gallon two 130 gallon	10'0"	23'6"
22PT250 24PT500 T/LT/WT	250 ton 500 ton	2 station 4 station	one 130 gallon two 130 gallon	11'6"	27'6"
32PT1510 34PT3200 S/LS/WS	150 ton 300 ton	2 station 4 station	one 130 gallon two 130 gallon	10'0"	30'0"
32PT150 34PT300 S/LS/WS	150 ton 300 ton	2 station 4 station	one 130 gallon two 130 gallon	10'0"	30'0"
 32PT2015 34PT4300 S/LS/WS	200 ton 400 ton	2 station 4 station	one 130 gallon two 130 gallon	10'0"	30'0"
32PT2520 34PT5400 S/LS/WS	250 ton 500 ton	2 station 4 station	one 200 gallon two 200 gallon	10'0"	30'0"
34PT5400 T/LT/WT	250 ton 500 ton	2 station 4 station	one 300 gallon two 300 gallon	11'6"	35'0"
32PT250 34PT500 L/S/WS	250 ton 500 ton	2 station 4 station	one 300 gallon two 300 gallon	10'0"	30'0"
32PT250 34PT500 T/LT/WT	250 ton 500 ton	2 station 4 station	one 300 gallon two 300 gallon	11'6"	35'0"
34PT8552 T/LT/WT	850 ton	4 station	two 400 gallon	13'2"	40'0"
 32PT2200 34PT4400 34PT5400 34PT6400 34PT660	200 ton 400 ton 500 ton 600 ton 660 ton	2 station 4 station 4 station 4 station 4 station	one 400 gallon two 300 gallon two 300 gallon two 300 gallon two 400 gallon	11'6" 11'6" 10'6" 11'6" 11'6"	32'0" 32'0" 28'1" 32'0" 33'0"

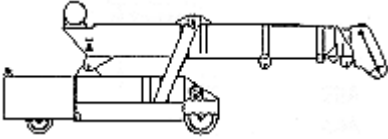
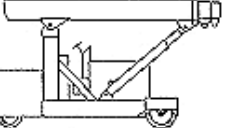
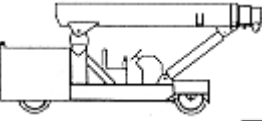
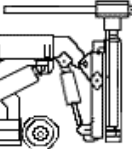
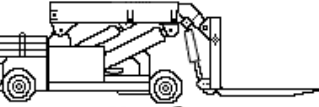
The Mobile Line

	MODEL	CAPACITY	LOAD REACH	LOAD HEIGHT	COMMENTS
	75MBL	75 ton	35'3"	40'6"	Forks Optional Jib Optional
	75TWL	75 ton	22'0"	37'6"	Forks Optional Jib Optional
	40TWLLP	40 ton	19'0"	30'4"	Forks Optional Jib Optional
	TF4560	30 ton	16'2"	27'7"	Mobilift Boom, Jib/Stinger Optional
	TR115T	115 ton	11'3" @ 36" Load Center	14'0"	
			N/A	N/A	Hydraulic platform trailers up to 30 Ton capacities available
	CT00001	250 ton	N/A	N/A	Nuclear Cask Transporter